

Chiave a bussola Poligonale

Wrench polygonal socket



Att:



Acciaio
Zincato

3/4"

1"

301 041	quadro 1"	41 mm
301 046	quadro 1"	46 mm
301 047	quadro 1"	47 mm
301 050	quadro 1"	50 mm
301 054	quadro 1"	54 mm
301 054 01	quadro 3/4"	54 mm
301 055	quadro 1"	55 mm
301 057	quadro 3/4" - Ford Transit	2" 1/4
301 058	quadro 1"	58 mm
301 058 01	quadro 3/4"	58 mm
301 060	quadro 1"	60 mm
301 063	quadro 1"	63 mm
301 065	quadro 1" - Mozzi Daily	65 mm
301 070	quadro 1"	70 mm
301 075	quadro 1"	75 mm
301 080	quadro 1"	80 mm

Chiave a bussola Esagonale

Wrench exagonal socket



Att:



Acciaio
Zincato

1"

301 110	Quadro 1"	mm 46
301 112	Quadro 1"	mm 48
301 114	Quadro 1"	mm 50
301 116	Quadro 1"	mm 52
301 118	Quadro 1"	mm 54
301 119	Quadro 1"	mm 55
301 120	Quadro 1"	mm 58
301 122	Quadro 1"	mm 60
301 123	Quadro 1"	mm 63
301 125	Quadro 1"	mm 65
301 128	Quadro 1"	mm 70
301 131	Quadro 1"	mm 75
301 134	Quadro 1"	mm 80

Chiave a bussola Esagonale lunga

Long wrench exagonal socket



Att:

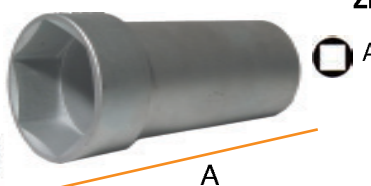

Acciaio
Zincato

1"

302 055	1"	mm 160	mm 55
302 060 20	1"	mm 200	mm 60

Bussola esagonale attacco 1"

Exsagonal Socket 1"



Att:

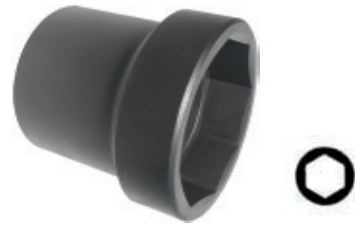

Acciaio
Zincato

1"

302 060	60 mm	302 100	100 mm
302 062	62 mm	302 102	102 mm
302 063	63 mm	302 103	103 mm
302 065	65 mm	302 105	105 mm
302 066	66 mm	302 106	106 mm
302 068	68 mm	302 108	108 mm
302 069	69 mm	302 110	110 mm
302 070	70 mm	302 112	112 mm
302 075	75 mm	302 113	113 mm
302 077	77 mm	302 114	114 mm
302 080	80 mm	302 115	115 mm
302 085	85 mm	302 116	116 mm
302 088	88 mm	302 118	118 mm
302 090	90 mm	302 120	120 mm
302 092	92 mm	302 123	123 mm
302 094	94 mm	302 135	135 mm
302 095	95 mm	302 140	140 mm
302 098	98 mm	302 140	140 mm

Chiave a bussola Ottagonale

Wrench Octagonal socket



Att:



Acciaio
Zincato

1"

303 060	Bassa - 60 mm	303 097	97 mm
303 065	Bassa - 65 mm	303 100	100 mm
303 068	Bassa - 2" gas	303 102	102 mm
303 070	70 mm	303 105	105 mm
303 075	75 mm	303 108	108 mm
303 078	78 mm	303 110	110 mm
303 080	80 mm	303 112	112 mm
303 082	82 mm	303 115	115 mm
303 083	83 mm	303 118	118 mm
303 085	85 mm	303 120	120 mm
303 086	86 mm	303 122	122 mm
303 088	88 mm	303 123	123 mm
303 090	90 mm	303 125	125 mm
303 094	94 mm	303 130	130 mm
303 095	95 mm	303 135	135 mm
303 096	96 mm	303 140	140 mm
303 097	97 mm		

Note:
303 086 per scania serie 4
303 100 per scania serie 4

Chiave a bussola Poligonale

Wrench polygonal socket

**Acciaio
Zincato**

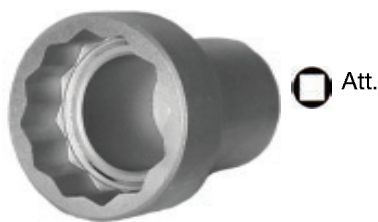

1"

		Att:	Ø
304 080	Cursor anteriore	1"	mm 80
304 085	Daily	1"	mm 85
304 090	Cursor anteriore	1"	mm 90
304 095	Cursor anteriore	1"	mm 95
304 100	Cursor anteriore	1"	mm 100
304 105	Cursor anteriore	1"	mm 105
304 110	Cursor anteriore	1"	mm 110
304 115	Cursor anteriore	1"	mm 115
304 120	Cursor anteriore	1"	mm 120
304 130	Cursor anteriore	1"	mm 130

Chiave a bussola Poligonale con canotto

Wrench polygonal socket



Att:



1"

305 090	Nuovo Eurocargò - mm 90
305 095	Nuovo Eurocargò - mm 95
305 100	mm 100
305 105	Cursor posteriore - mm 105
305 110	mm 110
305 115	mm 115

Bussola esagonale con canotto attacco 1"

Hexagonal socket with tube attack 1"



Att:



1"

306 085	Nuovi Eurocargò - 85 mm
306 090	90 mm
306 095	95 mm
306 100	100 mm
306 114	114 mm

Bussola esagonale pesante con foro di manovra trasversale

Hexagonal Socket

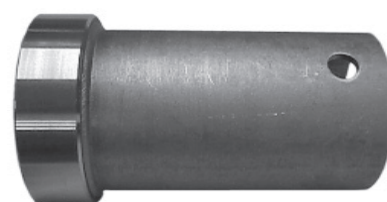

308 115	Lungh. mm 200 - mm 115
308 118	Lungh. mm 200 - mm 118

Chiave per ghiera a 5 denti mozzi Bus "Breda Menarini"

Wrench 5 teeth for Bus "Breda menarini"



Att 1"

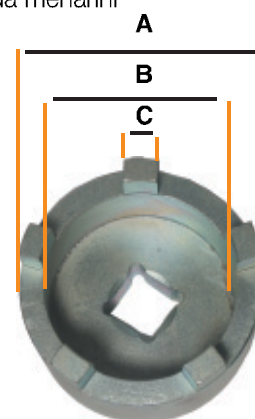

	Ø Est. A	Ø Int. B	mm C	Att.
309 005	80	63	11,5	1"

Chiave per ghiera a 10 denti mozzi Bus "Breda Menarini"

Wrench 10 teeth for Bus "Breda menarini"



**Acciaio
Zincato**



Att 1"

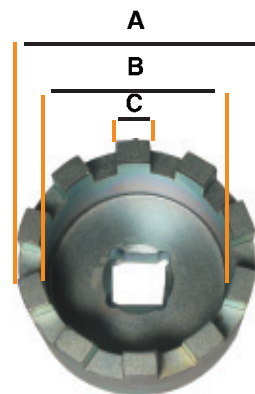

	Ø Est. A	Ø Int. B	mm C	Att.
309 010	80	63	11,5	1"

Chiave a T poligonale aperta per dadi tubazioni impianto di iniezione

T wrench polygonal open socket for nut pipe fitting



312 001	17 mm
312 002	19 mm

Chiave a T esagonale aperta per dadi tubazioni impianto di iniezione

T wrench exagonal open socket for nut pipe fitting



312 006 19 mm

Chiave poligonale aperta per dadi tubazioni impianto di iniezione

Wrench polygonal open socket for nut pipe fitting



312 011 17 mm

312 012 19 mm

Chiave esagonale aperta per dadi tubazioni impianto di iniezione

Wrench exagonal open socket for nut pipe fitting



312 015 17 mm

312 016 19 mm

Chiave esagonale aperta per valvola solenoide

Wrench exagonal open socket for solenoid valve

021



022



312 021 CAV - 24 mm

312 022 Bosh EP/VE - 24 mm

Set chiavi a 4 denti per montaggio-smontaggio ghiere iniettori Truck

Toothed socket for truck diesel pressure and injector man-mercede

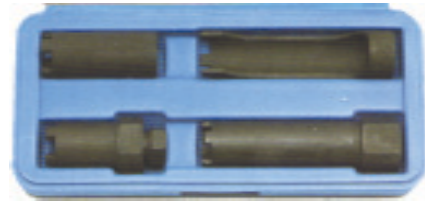

312 028 Pz 4

Chiave per ghiere porta iniettori autocarri Mercedes

Key for Injector Truck Mercedes

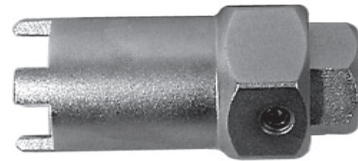

312 029 28.5x22.5x7.5

Chiave smontaggio ghiera portainiettori

Wrench for dismantling pre chamber injection



312 030 Mercedes Man.L. 80 - A27xB22xC8

312 031 Mercedes Man.L. 150 - A27xB22xC8

Estrattore astucci portainiettori

Puller for nozzle holder



312 032

Estrattore astucci portainiettori

Puller for nozzle holder

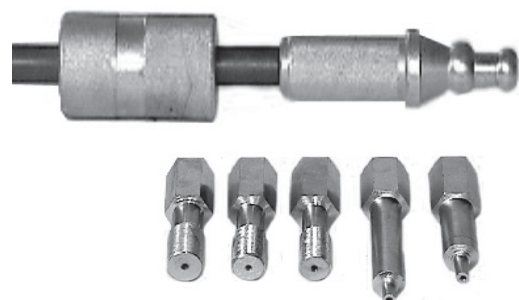

312 033 22x1.5 - 24x1.5 - 3/4" gas

Alesatore guidato con fresa conica elicoidale e rondelle di spessoramento per astucci rame porta iniettori

Reamer with helical conical miller and shimming aluminium washers for nozzle holder copper cases

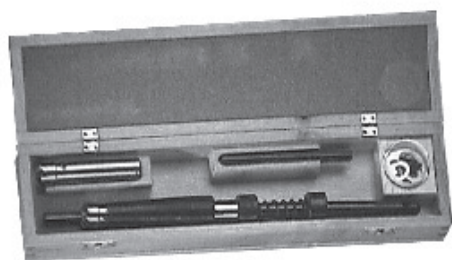

312 035 Fiat Iveco - 22 mm

Alesatore guidato con frese coniche elicoidali e rondelle di spessoramento per astucci rame porta iniettori

Reamer with helical conical miller and shimming aluminium washers for nozzle holder copper cases

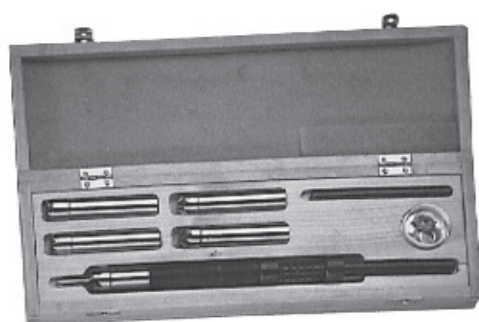

312 036 Fiat Iveco Elicoidale - 22 mm
Piana - 22 mm
Elicoidale - 20,5 mm
Volvo Man - 21 mm

Alesatore guidato con 1 fresa conica per Daily e 1 fresa piana per Ford Transit

Reamer with 1 conical miller for Daily and 1 plane miller for Ford Transit



312 037 Alesatore guidato
312 038 Fresa ricambio conica per Daily
312 039 Fresa ricambio piana per Ford Transit



Estrattore parafiamma

Puller for flame dampers



312 040 Universale

Attrezzi distacco tubi carburante su serbatoi Iveco Stralis, Eurotech, Eurocargo e simili

Tool release fuel lines

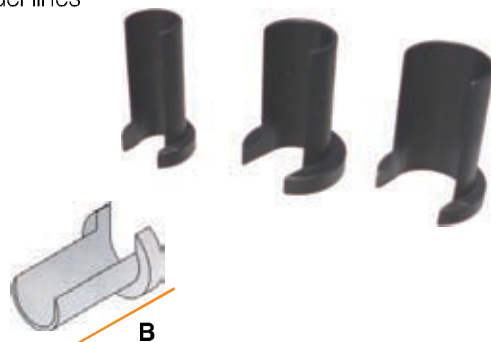

312 051 Pz 3

Ricambi - Spare parts

	A	B
312 051 01	11	35
312 051 02	14,5	35
312 051 03	17,5	35

Attrezzo rotazione albero motore per la registrazione delle punterie

Tool for engine rotation during clearance tappets

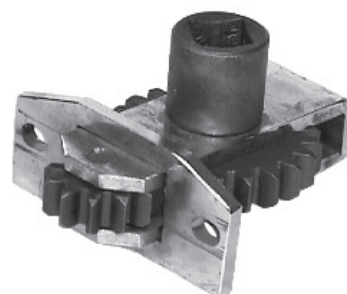

313 002 Iveco 170
313 003 Iveco 330
313 004 Iveco 190.36
313 005 Iveco 190.42

Attrezzo rotazione albero motore per la registrazione delle punterie

Tool for engine rotation during clearance tappets

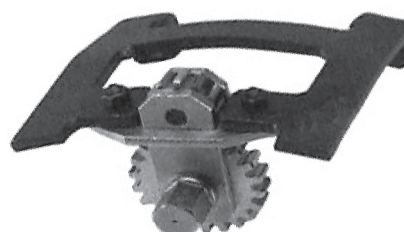

313 009 Iveco 330-30
313 010 Daf 95

Attrezzo rotazione albero motore per la registrazione delle punterie triplo ingranaggio

Tool for engine rotation during clearance tappets



- 313 011 Mercedes 6/8/10 cil.
- 313 012 Mercedes Actros - Atego

Attrezzo rotazione albero motore per la registrazione delle punterie

Tool for engine rotation during clearance tappets

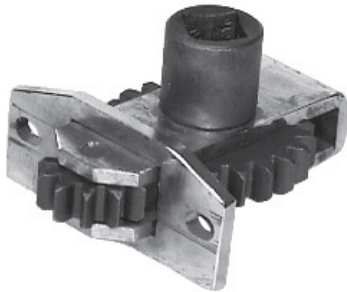

- 313 015 Eurocargo-Eurotec-190 38/T/P/PT-190
42/T/P/TP - 220 38/PT-330 35 H/HT/HW-Bus
370 12 25- 240 38/P/PT

Attrezzo rotazione motore per registro punterie telescopico

Tool for engine rotation during clearance tappets

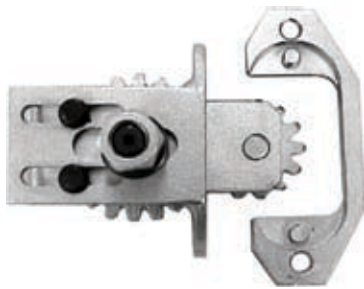

- 313 018 Eurocargo

Attrezzo rotazione albero motore per la registrazione delle punterie

Tool for engine rotation during clearance tappets



- 313 020 Volvo F 13
- 313 021 Volvo F 12

Attrezzo rotazione albero motore per la registrazione delle punterie

Tool for engine rotation during clearance tappets



- 313 022 Renault
- 313 023 Renault match 500

Chiave registro vite bilancieri comando valvole a tacca

Wrenches two rocker arm adjusting screw



- 313 025 14 mm
- 313 026 17 mm

Chiave registro vite bilancieri comando valvole a cacciavite

Wrenches two rocker arm adjusting screw



- 313 027 17 mm

Chiave Torx per testata cilindri MAN

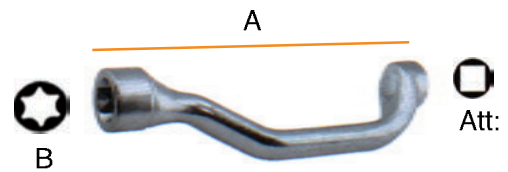

- | | Att: | A | B |
|---------|------|--------|------|
| 313 900 | 1/2" | mm 165 | E 20 |

NOTE

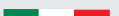

Estrattore canne cilindri

Remover and replacer sleeve



- 314 000 Con Flangie mm 122 - 125
- 314 001 Con flangie mm 122 - 125 - 131,5 - 137 - 145

Ricambi - Spare parts



- 314 002 Flangia mm 131,5
- 314 003 Flangia mm 137
- 314 004 Flangia mm 145

Attrezzo compressione e rilievo sporgenza canne cilindri

Tool for compressing and releasing cylinder



- 314 005 8340.04-8340.05-8360.05

Supporto con comparatore per controllo altezza canne cilindri

Plate gauge for checking cylinder liner height



- 314 007 CO3, CP3, 8340.04, 8360.03, 8360.05

Ricambi - Spare parts

- 314 008 Solo supporto



Made in Italy

Estrattore mozzo puleggia su albero motore

Puller crunkschaft pulley hub



- 314 009 650, 662, 682, 690, 69NT, OM804, 693, 697, 690N4, 684, 691, 180

Estrattore ritegno volano durante il fissaggio su albero motore

Flywhell restrainer



- 314 012 Iveco 190 turbo

Estrattore ingranaggio albero distribuzione

Puller for flywhell distribution



- 315 001 Iveco 190, 190.42, 190.38, 170

Attrezzo centraggio coperchio distribuzione



- 315 003 Fiat 242 Diesel

NOTE



Centrafrizione universale Truck

Universal tool for adjusting clutch plates truck



Acciaio - Brunito



321 010

Chiave Eurocargo



321 001 Kit con attrezzo + 6 boccole di centraggio

321 011 Kit con attrezzo + 6 boccole + chiave Eurocargo

Ricambi - Spare parts

321 010 Chiave centraggio frizione Eurocargo

Attrezzo per sollevamento albero primario



322 003 ZF 170.33, 190.33, 370

Attrezzo per registrazione forcella comando spliter



322 010 ZF Ecosplit 16S, 130S, 160

Estrattore albero e cuscinetti retromarcia

Puller for reverse shaft



322 021 Fuller 170 NC 33

Chiave per ghiera albero frizione

Main shaft nut wrench



322 022 Fuller 170 NC 33

Attrezzo sollevamento e bilanciatura albero primario e secondario

Gearbox mainshaft lifting and balancing



322 023 Fuller 170 NC 3

Estrattore cuscinetto surmoltiplicata

Puller for bearing balls reduction gear



322 025 Fuller 170 NC 3

Estrattore smontaggio cuscinetti posteriori scatola ausiliaria

Remover for auxiliary gearbox ball bearings rear



322 030 Fuller 170 NC 33-190 NC 33

Estrattore smontaggio cuscinetti albero secondario

Remover for countershaft gearbox ball bearings



322 031 Fuller 170 NC 33-190 NC 33 - 100 mm

322 032 Fuller 170 NC 33-190 NC 33 - 110 mm

Chiave ghiara albero secondario

Wrench countershaft ring nut



322 033 80NC-90NC-100NC-N100-110R-110P-130-130R-110AI-130AI-314.3

Chiave dado fissaggio albero presa diretta

Wrench inputshaft nut



322 034 Fuller 170 NC 33-190 NC 33 - 80 mm

Chiave ghiera ridotta

Wrench for low PTO ring nut



322 039 697

Chiave ghiera albero di trasmissione

Wrench for mainshaft ring nut

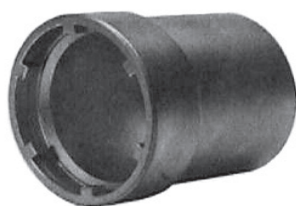

322 040 190.42 - Ghiera Ø Est. 75 Ø Int. 68

Chiave registrazione gioco cuscinetti conici albero secondario

Wrench adjusting bevel drive pinion locknut



322 042 OM 50-55-65-70-75-50 NC

Chiave ghiera registro cuscinetti semiassi

Wrench for adjusting axle nut



322 043 626-640-642-Super Taurus

Chiave ghiera ritegno cuscinetto ingranaggio riduzione silenziosa

Wrench for gearbox silent reduction drive gear bearings lock nut



322 044 682 N2-682N3-690N1-306-411

Chiave ghiera presa diretta cambio flangiato

Wrench for mainshaft flange adjusting nut flanged only



322 046 E100 - 90 mm

Chiave ghiera albero presa diretta cambio flangiato

Wrench for take off shaft adjusting nut only for flanged gearbox



322 048 E100

Chiave ghiera albero presa diretta

Wrench for take off shaft adjusting nut



322 050 190.38 - 73 mm

Chiave ghiera albero presa diretta

Wrench for take off shaft adjusting nut

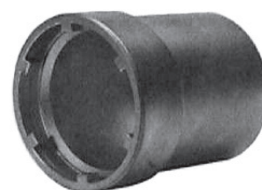

322 052 Berliet - 68 x78x6

Chiave per ghiera albero trasmissione

Wrench for take off shaft adjusting nut



Acciaio Cr. Mo. -
Brunito

Att 3 / 4"



322 053 SCANIA - Att 3/4" - 64 x 70 x 7

Chiave ghiera albero retarder

Wrench for take off retarder shaft adjusting nut



313 054 Scania 42x52x5

313 055 Scania 64x74x6

Chiave ghiera albero retarder

Wrench for take off retarder shaft adjusting nut

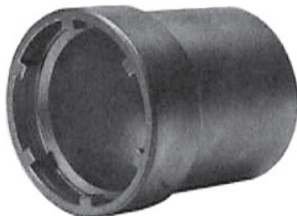

322 058 Renault - 65x77x7

322 059 Renault - 90x102x7

Estrattore silentblok c/cuscinetto reggispinta

Puller for gearbox silentblok



322 063

Estrattore cuscinetti cambio

Puller for gearbox ball bearing



322 070 Universale Fiat Om

322 071 Estrattore a campana

322 072 Coppia semianelli 70 mm

322 074 Coppia semianelli 90 mm

322 075 Coppia semianelli 100 mm

322 076 Coppia semianelli 110 mm

322 080 Coppia semianelli/ 120 mm

322 078 Flangia per coppia semianelli sino 120

322 081 Coppia semianelli 130 mm

322 085 Coppia semianelli 138 mm

322 082 Coppia semianelli 140 mm

322 083 Coppia semianelli 150 mm

322 084 Coppia semianelli 160 mm

322 086 Flangia per coppia semianelli sino 160

Chiave ghiera albero presa diretta

Wrench for take off shaft adjusting nut

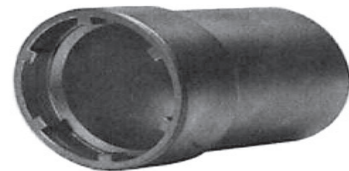

322 100 2838.5-
Eurocargo 60E10/12/14-65E10/14-75E12/14

322 101 2845.5/6-2866.6-
Eurocargo 80E15/18-100E15/18

322 102 2865.6-
Eurocargo 80E21-100E21-180E12T

Chiave ghiera albero presa diretta

Wrench for take off shaft adjusting nut

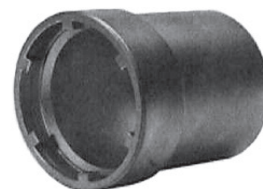

322 105 Scania 48x55x6



Estrattore flangia pignone conico

Puller for bevel pinion



322 110 190 Turbo

Estrattore flangia pignone conico

Puller for bevel pinion



322 111 682-697-684 diam. 180 mm

Attrezzo con particolari di reazione per estrazione corona conica dal pignone cilindrico

Puller for removal differential ring gear

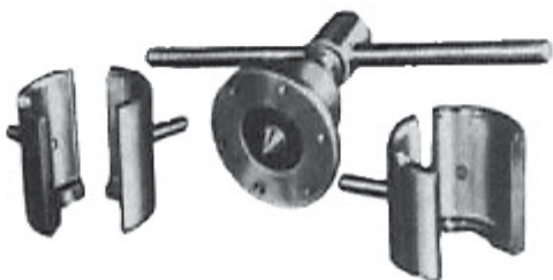

322 120 490928D.R.

Chiave ghiera registro cuscinetti semiscatola

Wrench adjusting half case bearings nut

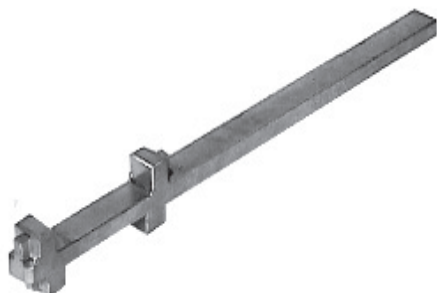

322 127 190.42

Attrezzo posizionamento cuscinetto interno pignone cilindrico

Tool for positioning internal pinion ball bearing



322 129 190.42

Chiave bloccaggio e sbloccaggio albero differenziale

Wrench for locking differential shaft



322 131 190.42

Chiave braccetti sterzo TRUCK



Acc. Cr. Mo. - Brunito



Att 3 / 4"

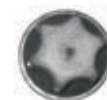

330 100 Att. 3 / 4" - Torx 100

Estrattore volante guida

Puller driving wheel



331 001 Universale

Estrattore volante guida

Puller driving wheel



331 003 Gamma Z /M/T/P/PA-Turbostar autobus

Chiave valvole compressore

Wrench for compressor



331 011 Marelli OM FIAT

Chiave valvole compressore

Wrench for compressor



331 013 626-642-666-680-682

Chiave valvole compressore

Wrench for compressor nut



331 015 Westinghouse

Chiave ghiere sterzanti

Wrench for nut steering pads

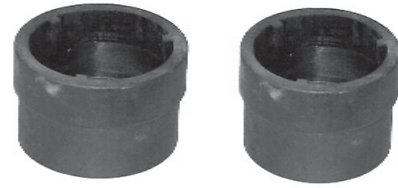

331 017 Adige Viberti

Chiave registro cuscinetto mozzo anteriore e posteriore

Spanner for wheel hub bearings adjusting collar or nut



333 001 643N-650N2-662N2/N3-673N-100/NC-110-130NC-120 Tigrotto65

Chiave registro cuscinetto mozzo anteriore

Spanner for wheel hub bearings adjusting collar or nut

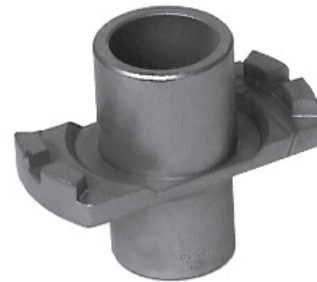

333 002 645N-650N-650E-314 Post. 314-650F

Chiave registro cuscinetto mozzo posteriore

Spanner for wheel hub bearings adjusting collar or nut



333 003 697-684-683-tITANO-619N-643EP-690N3-694N4-619NI-343-331A-682N4-619N1-180-160-170.26-190.26

Chiave registro cuscinetto mozzo anteriore

Spanner for wheel hub bearings adjusting collar or nut

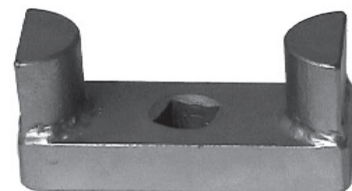

333 005 330

Chiave registro cuscinetto mozzo ponte intermedio

Spanner for medium wheel hub bearings adjusting collar or nut

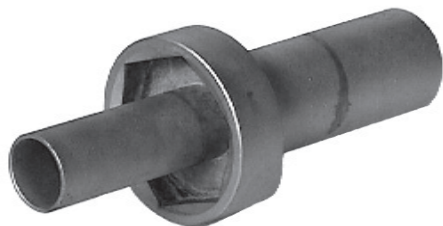

333 007 697N-300PC-Titano6x4-OM260-300-418-421 90 mm

Estrattore barre di reazione fra i due ponti

Puller for rear wheel reaction rod



333 008 693-697-300

Estrattore mozzo anteriore

Puller front hub



333 010	Leoncino-Lupetto-Tigrotto	60x1.5
333 013	Mercedes 330	80x1.5
333 015	Eurocargo	80x2.0
333 017	OM80NC-90NC	85x1.5
333 020	Mercedes 330	89x1.5
333 023	642-645-650-314	90x2.0
333 025	684N-309-160-	95X2.0
333 029	Renault	100x1.5
333 031	Man19422-19372-33422	114x1.5
333 032		115x1,5
333 033	682N-619N1-690N1-690N4 act.	115x2.0
333 036	BPW-Eurotech	125x2.0
333 039	683-684-693-Titano-343-190-170 ect	130x2.0
333 043	rimorchi Zorzi	175x2.0
333 045	Ecomas	125x2.

Chiave registro cuscinetto mozzo ruote posteriori

Spanner for wheel hub bearings adjusting collar or nut

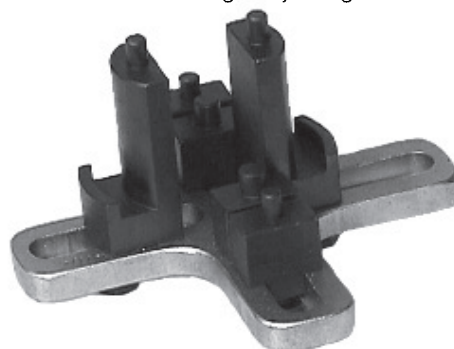

333 050 Universale registrabile

Chiave dado mozzo ruote posteriori

Spanner for rear wheel nut



333 051 Eurocargo - 85 mm

Chiave dado mozzo ruote

Spanner for wheel nut



333 052 Eurocargo - 65 mm

333 053 Eurocargo Eurotek - 95 mm

Estrattore mozzo ruote

Puller for hubs



333 056 Iveco 115.17 Ant.

333 057 Iveco 115.17 Post. rear

Estrattore mozzo ruote

Puller for hubs



333 058 Iveco 109-115-135-145 Ant.

333 059 Iveco 109-115-135-145 Post. rear

Chiave per dadi mozzi BPW ECO

Acciaio -
Brunito



Att 1"



333 062 Att. 1" - mm 65

333 063 Att. 1" - mm 80

Chiave coprimozzo ruote

Universal socket for wheel hub bearing



333 064 BPW ECO 110 x 104

333 067 VIBERTI 108 x 103

333 069 BPW 95 x 90

333 070 BPW 93 x 88

333 071 Eco - BPW 120 x 115

333 071 10 Eco - BPW 120 x 115C/K

Chiave ghiera mozzo ruote posteriori

Wrench for rear hubs nut



333 072 Mercedes 1113-1117-1217 - 84 mm

333 073 Mercedes 1919-Man 12-19 - 114 mm

Chiave per ghiera mozzi a 6 denti con canotto



333 074 Dente - Int./Est. Ø98/106 Largh. 14

Chiave ghiera mozzo ruote posteriore



333 075 Mercedes 814

Chiave per ghiera 6 Denti mozzi poster. MAN ALE



Acciaio -
Zincato

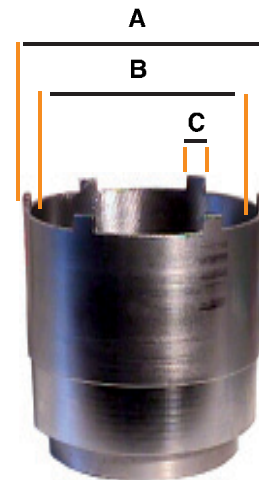

Att 1"

	Ø Est. A	Ø Int. B	mm C	Att.
333 076	119	110	11x4,5	1"

Chiave ghiera mozzo posteriore

Socket for wheel hub bearing

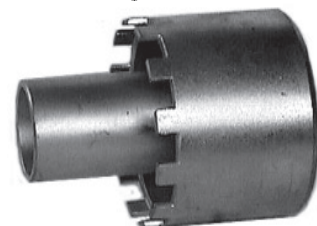

333 077 12 Denti Ø int. 100 Ø est. 110

333 078 12 Denti Ø int. 105 Ø est. 115

333 079 12 Denti Ø int. 115 Ø est. 125

Chiave ghiera mozzo ruote posteriori

Wrench for rear hubs nut

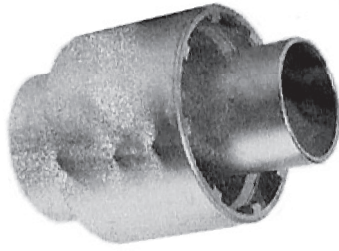

333 080 Mercedes 0404-man 12-332 8 denti - 98 mm

Chiave per ghiera 8 Denti. Per mozzi



Acciaio -
Zincato

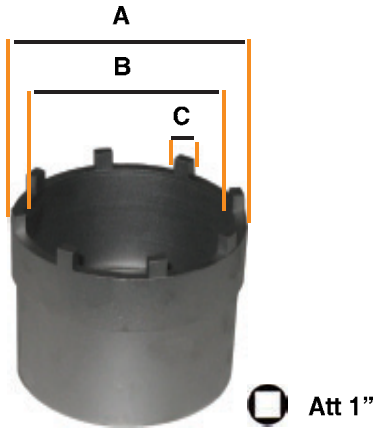

	Ø Est. A	Ø Int. B	mm C	Att.
333 081	106	95	8	1"

Chiave per ghiera 6 Denti interni per mozzi



Acciaio -
Zincato

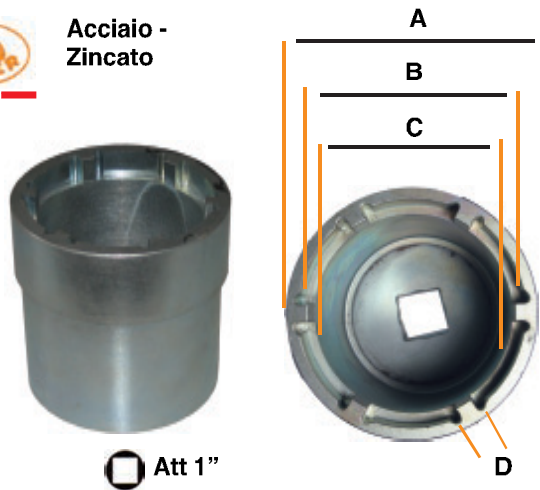

	Ø Est. A	Ø Int. B	Ø Int. C	mm D
333 083	112	98	89	8

Chiave ghiera mozzo posteriore

Socket for wheel hub bearing

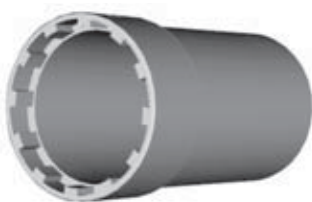

333 084	12 Denti interni - Mercedes Bus 303 - 99x108
333 086	6 Denti interni - Breda - 100x110
333 087	6 Denti interni - 121x131

Chiaveghiera 4 denti mozzo posteriore Renault Mascot & Traffic

4 tooth socket for wheel hub bearing

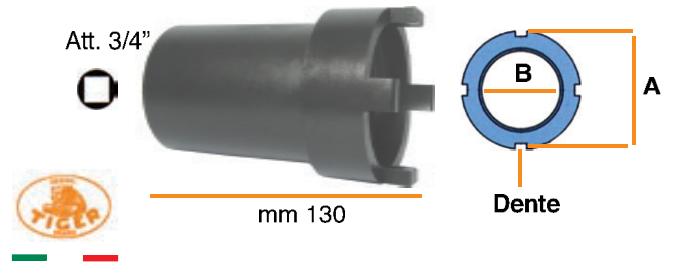

	Att.	Dente	A esterno	B interno
333 085	3/4"	13	mm80	mm 65

Bussola esagonale ribassata per mozzo posteriore

Renault Mascot & Traffic

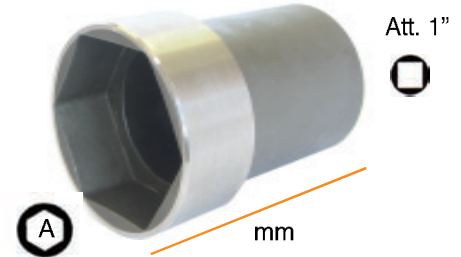

	Att.	A	mm
333 085 01	1"	mm77	130

Estrattore mozzo ruote

Puller for hubs



333 090 Leoncino-Tigrotto-Lupetto Post. rear

Chiave ghiera registro cuscinetti mozzo ruote posteriori

Wrench for adjusting rear hubs nut



333 092 Iveco 190 Ecosplit

Chiave ghiera registro cuscinetti mozzo ruote

Wrench for adjusting rear hubs nut



- 333 094 Gamma Z Turbo 80 mm
- 333 095 Gamma Z Turbo 87 mm
- 333 096 Gamma Z Turbo 92 mm

Chiave ghiera registro cuscinetti mozzo ruote posteriori

Wrench for adjusting rear hubs nut



- 333 098 Daily - 74 mm
- 333 099 Daily - 76 mm

Chiave ghiera perno balestra anteriore

Wrench for front suspension nut



- 333 100 Magirus-330

Chiave per perni balestre Volvo

Tool for leaf spring pivot



- 333 101

Coppia perni balestre SCANIA



- 333 101 10



Chiave dado bloccaggio e registro cuscinetto mozzo ruote ponte intermedio e posteriore

Wrench for locking and adjusting hubs ball bearing



- 333 102 697N-300PC-418-421 - 90 mm

Chiave dado mozzo ruote anteriori

Wrench for front hubs ring nut



- 333 104 693N-683N-619N
- 333 106 643N-309

Chiave dado mozzo ruote posteriori

Wrench for rear hubs ring nut



- 333 108 242 Diesel

Estrattore cuscinetti mozzi posteriori

Puller for rear hubs ball bearing



- 333 110 Volvo F12

Estrattore cuscinetti mozzi

Puller for hubs ball bearing



333 114 330-190.38-190.35 Turbo

Chiave calotte mozzo ruote

Wrench for hubs nut



333 130 619N - 60 mm

333 132 682-692 - 65 mm

333 134 Leoncino35/40-50-55-60-65-70-75-329 - 70 mm

333 136 680-682N4-690N1/N4-306-411-180NC - 100 mm

333 138 102 mm

333 139 682N2 - 130 mm

333 140 Viberti-Card - 140 mm

Chiave a 6 denti per asse posteriore

Groove nut socket with 6 studs



mm
200



3/4"

	A-esterno	B-interno	Dente
333 150	125	115	10

Campo di applicazione - Range

Mercedes benz Actros

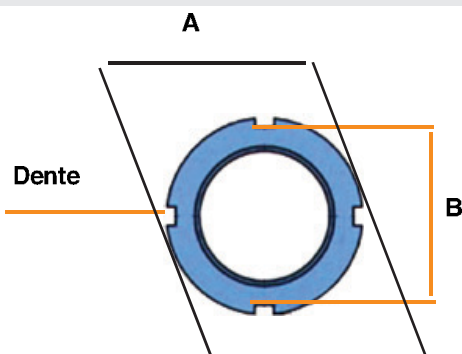

Chiave a 6 denti esterni, con canotto, per asse posteriore

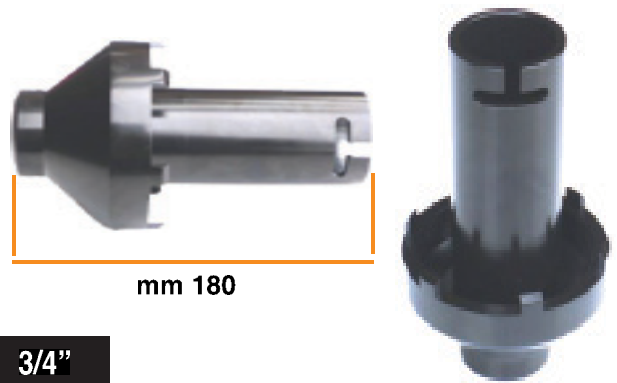

mm 180

3/4"

	A-esterno	B-interno	Dente
333 152	95	87	10

Campo di applicazione - Range

Mercedes benz ATEGO HL2, 814 Vitaro 814 - MAN ecc...

Chiave a 6 denti interni, con canotto per albero riduttore



mm 160

3/4"

	A-esterno	B-interno	Dente
333 156	148	118	11

Campo di applicazione - Range

MAN-TGA Asse frontale, V9 - 82L - 01 Freni a disco/ABS ecc

Chiave a 6 denti per asse, disco freno, ABS ecc..

Groove nut socket with 6 studs



mm
110



3/4"

	A-esterno	B-interno	Dente
333 160	148	118	11

Campo di applicazione - Range

MAN-TGA Asse frontale, V9 - 82L - 01 Freni a disco/ABS ecc

Estrattore leva comando frizione sterzo trattori

Puller for lever on clutch steering wheel tractors

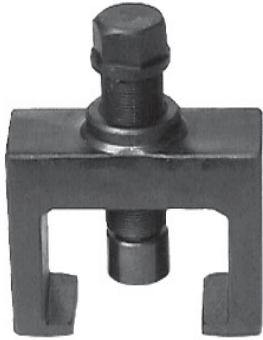

333 200 52-55-60-70-80-FL

Estrattore pignone su piatto frizione sterzo trattori

Puller for pinion on plate on clutch steering wheel tractors

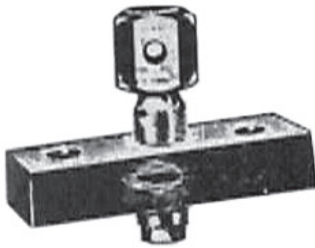

333 202 52-55-60-70-80-FL

Estrattore tamburo interno frizione sterzo trattori

Puller for axle on clutch steering wheel tractors



333 204 52-55-60-70-80-FL

Estrattore molle frizione sterzo trattori

Puller for coils on clutch steering wheel tractors

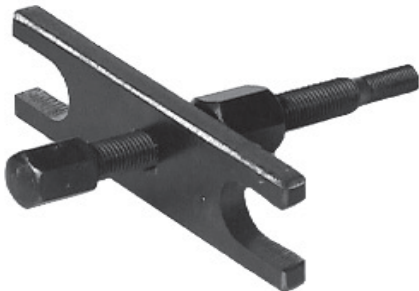

333 206 52-55-60-70-80-FL

Estrattore perni di giunzione catenarie trattori

Puller for pins of chaintractors



333 210	25C-311-312-352-531	10x1.25
333 211	411-451	14x1.5
333 212	OM35-40-45-50C	16x1.5
333 213	52-55-60-70-80-FL	20x1.5

Estrattore tamburi ceppi freno

Puller for brake hubs



333 215	Universale
333 216	Zampa Ricambio

NOTE



Estrattore a traversa chiusa per mozzi e tamburi freno TRUCK, fornito con 5 coppie di tiranti intercambiabili

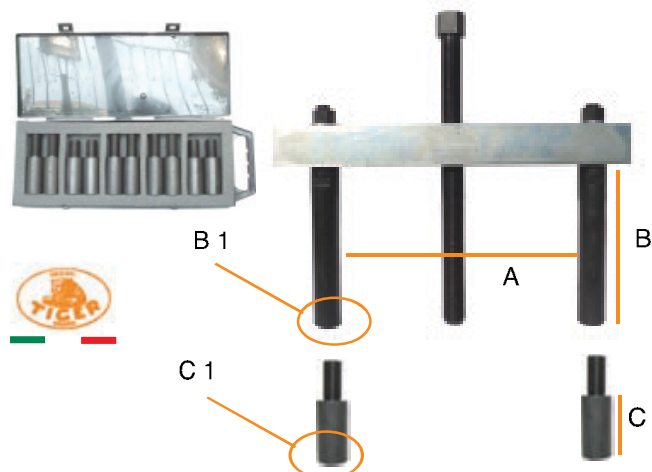

333 230 Estrattore fornito con 5 coppie di tiranti
A min 140 - max 370 - 15 Kg

Ricambi - Spare parts

333 230 05 kit 5 tiranti in comoda valigetta
(di serie con 333 230)

		B 1	B
333 230 22	Coppia colonne	22 x 1,5	200
		C 1	C
333 230 18	Coppia tiranti	18 x 1,5	70
333 230 20	Coppia tiranti	20 x 1,5	70
333 230 21	Coppia tiranti	20 x 2	70
333 230 78	Coppia tiranti	11G 7/8"	70
333 230 79	Coppia tiranti	14G 7/8"	70

Adattatori opzionali - Optional adaptor

		B 1	B
333 230 23	Coppia colonne	22 x 1,5	100



Particolare del tirante con prigioniero filetto femmina per mozzi e tamburi Truck

Esempi di utilizzo - Examples of use

Motrici:

- Coppia tiranti mm 18 x 1,5 **Iveco Daily**
- Coppia tiranti mm 20 x 1,5 **Mercedes**
- Coppia tiranti mm 22 x 1,5 **Astra - DAF - Renault - Mercedes**
- Coppia tiranti mm 18 x 1,5 / 20 x 1,5 / 22 x 1,5 **Iveco Truck**
- Coppia tiranti 7/8" **Scania - Volvo**

Rimorchi e semirimorchi:

- Coppia tiranti mm 22 x 1,5 **Acerbi-fruehauf / Adige-umberti**
- **Austeras / Bartoletti / Battaglino-bpw / BPW / Cardi / Minerva**
- **ROR-meritor / Otto saver saf**
- Coppia tiranti mm 20 x 2 **Raggiere Adige viberti**
- Coppia tiranti 7/8" **Battaglino-bpw**

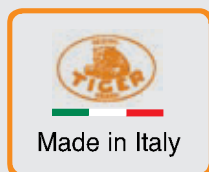

Kit carrellato per estrazione e introduzione oleopneumatico per estrazione boccole in acciaio, bronzine dalle balestre e silentblock

Hydro-pneumatic puller / tacker-in for bushings and silentblock

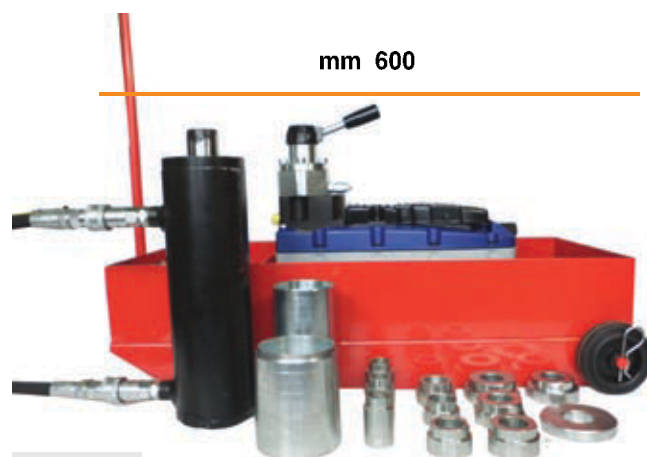

334 214

Composizione - Composition

- NR:
- 1 - Pompa oleopneumatica
 - 2 - Carrello completo di ruote e di porta accessori
 - 3 - Manico di movimentazione
 - 4 - Leva di selezione operazione "estrazione - inserimento"
 - 5 - Pedale di comando
 - 6 - Tubi di collegamento con innesti
 - 7 - Cilindro per l'estrazione e/o il reinserimento
 - 8 - Serie di boccole con tamponi: Ø 59.2 x 49.4 - Ø 53.7 x 44.4 - Ø 49.6 x 44.6 - Ø 44.8 x 39.7 - Ø 42.0 x 34.7 - Ø 39.4 x 34.1 - Ø 34.7 - 29.5
 - 9 - Serie di boccole filettate Ø 31.7 x 24.1 - Ø 29.7 x 23.3 - Ø 26.7 x 21.9
 - 10 - Anelli di spinta Ø 85.0 x 30.5
 - 11 - Viti di prolunga: Ø 60.3 x 49.5 x h=133 - Ø 76.1 x 62.0 x h=100
 - 12 - Spezzoni di prolungamento: mm 200 - mm 300

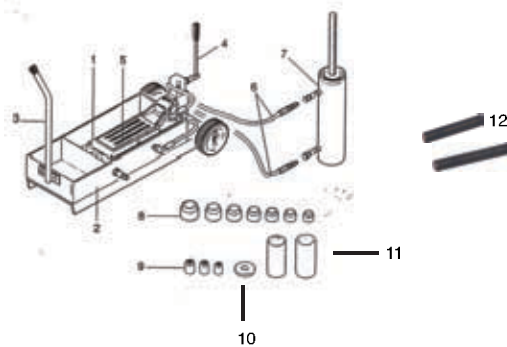

Dati tecnici - Informative

- *Pistone tipo oleodinamico a doppio effetto
- *Potenza di trazione del pistone: 12.500Kg
- *Pressione aria per alimentazione della pompa: 7/8 bar
- *Pressione erogata della pompa: 400 bar

Adattatori opzionali - Optional adaptor



334 214 04 Kit 4 boccole per rimorchi e semirimorchi



334 214 08 Kit 8 boccole per Eurotech D55 - 60

Estrattore per perni montati su rimorchi, semirimorchi e simili

Pin extractor, conceived in order to draw pins out of trailers or or semitrailers' suspensions

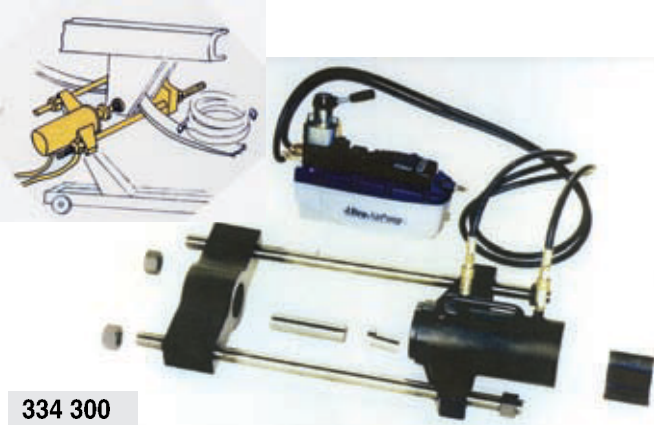

334 300

Dati tecnici - Informative

La macchina è composta da un pistone dotato di flange laterali, di una controflangia con tiranti e di una pompa di tipo oleopneumatico per l'azionamento del pistone. Il tutto è contenuto in un carrello montato su ruote.

- *Pistone di tipo oleodinamico a doppio effetto
- *Potenza di spinta del pistone = 55 ton
- *Pressione aria di entrata alla pompa = 7 atm
- *Pressione erogata dalla pompa = 700 atm

Estrattore perni ganasce freni

Puller for brake pins



335 002 170 NC

NOTE



Attrezzo registro freni

Tool for agjusting cylinder brake



335 006 Stop master

335 008 Nuovi impianti

Calettatore per montaggio guarnizioni di tenuta cilindri freno

Installer for brake cylinder seal



335 010 Stop master

335 011 Eurotech

335 012 Eurocargo

Attrezzo registro freni

Tool for agjusting cylinder brake



335 015 Stop master

Attrezzo registro freni

Tool for agjusting cylinder brake



335 016 Stop master

Attrezzo registro freni

Tool for agjusting cylinder brake



335 017 Stop master

Leva registro freni a mano DAILY



335 025

Alesatori montanti fusi a snodo

Reamer knuckle bush



335 100	110-130-100/10-650N-662	27x34 mm
335 102	160-643-684	32x40 mm
335 104	Gamma Z	34x42 mm
335 106	170-190-418-421-370-150NC	41,3x50.8 mm
335 108	Arcom-Battaglino-Marotta190-260	45x50 mm
335 110	Ceschi-Rigo	47x52 mm
335 112	Calabrese	50x55mm
335 114	Arcom	50x60 mm
335 116	Zorzi	51x56 mm
335 118	Arcom	55x60 mm
335 120	Ceschi-Rigo	65x72 mm

Moltiplicatore di coppia manuale per TRUCK

Increasing length save labour wrench



335 200 In valigetta

Dati tecnici - Informative

Moltiplicatore di coppia con bussole da mm 32 & 33 attacco 1" Utilizzato per rimuovere i bulloni di tutti i tipi di ruote dagli autocarri. Semplice da utilizzare e facile da trasportare grazie alla sua valigetta. Forza massima 4800 Nm, pari a 480 Kg.



Moltiplicatore di forza oleodinamico per smontaggio dadi ruota autocarri

Couple multiplier for trucks wheels nuts



335 201

Chiave a T doppio esagono dadi ruote autocarri

Wrench for wheels nuts



- 335 305 Diam. 23 x 370 mm - 24x27 mm
- 335 308 Diam. 23 x 370 mm - 30x32 mm

Chiave a girabacchino dado fissaggio ruota

Wrench for wheels nuts



335 321 Lung. 370 - 27 mm

Chiave a girabacchino dado fissaggio ruota con unghia

Wrench for wheels nuts



335 322 Lung. 370 - 27 mm

Chiave a girabacchino dado fissaggio ruota con unghia

Wrench for wheels nuts



335 325 3/4"

